

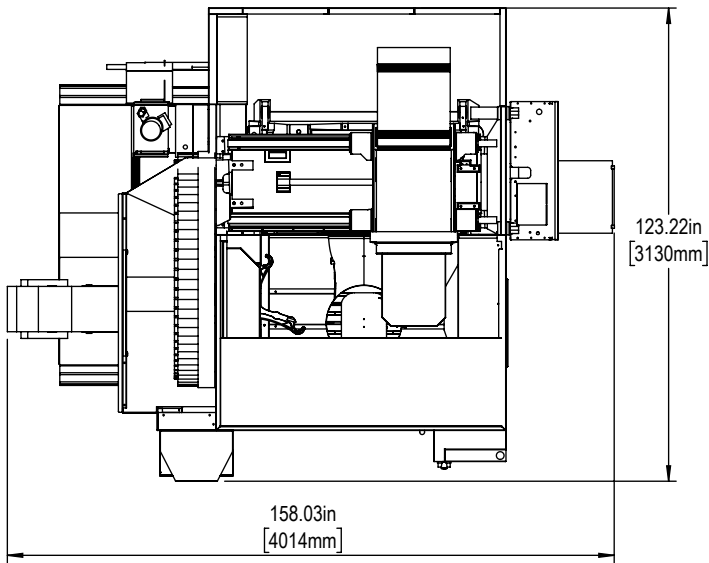

Installed Dimensions

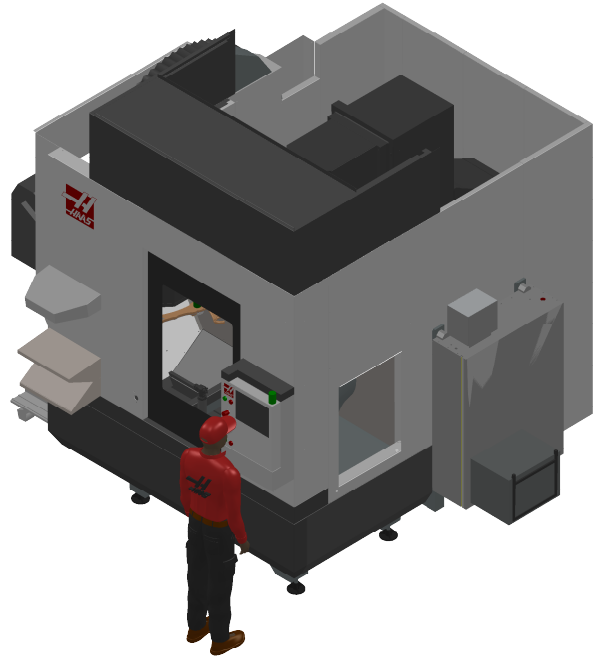

Leveling Pad Height

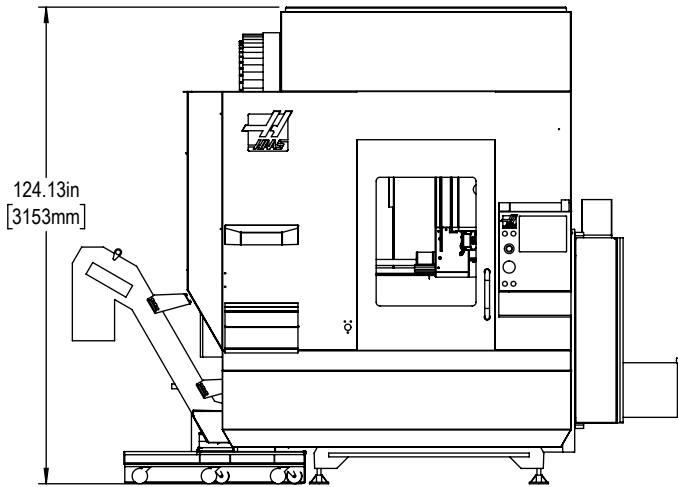
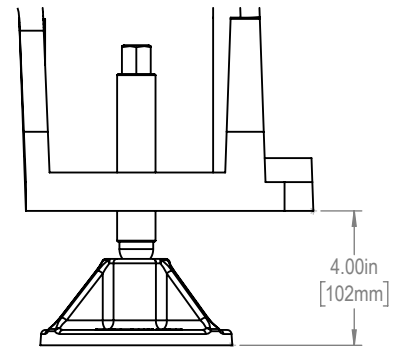

*All Height Dimensions Based on Suggested Leveling Pad Height

Shipping Dimensions

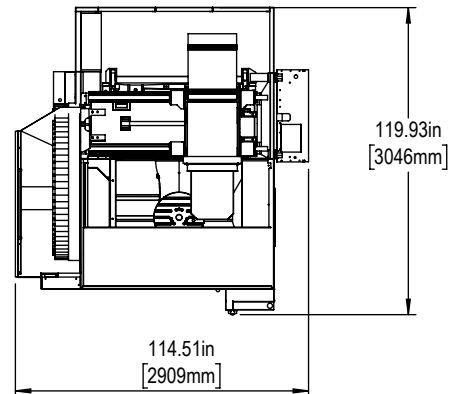
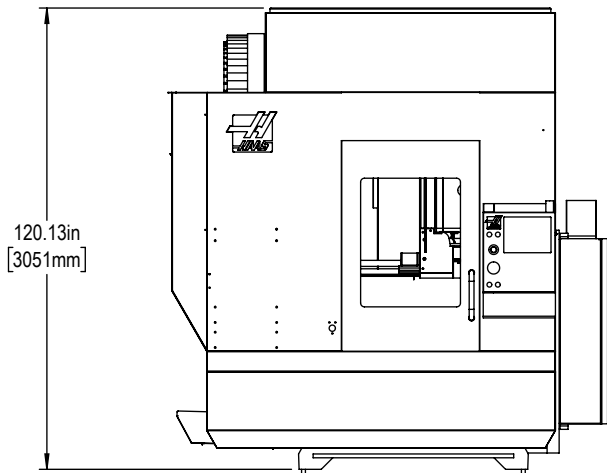

Air & Power

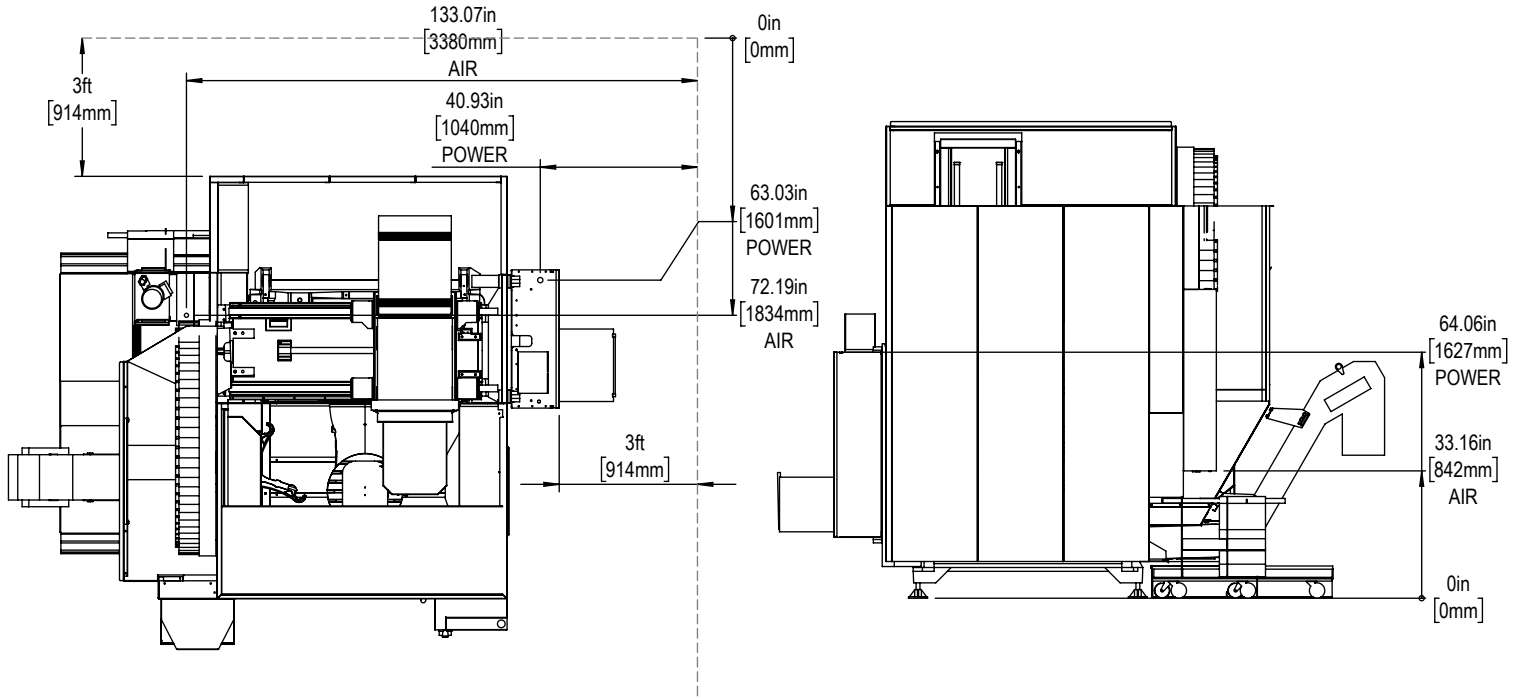

Maintain 3 feet [915mm] clearance to the nearest obstruction around all sides of machine perimeter for maintenance access

Note:
Machine must be placed on one continous concrete slab. Slab should extend 12in [305mm] beyond anchor holes in all directions

Anchor Pattern

Anchor Hole Detail
 Ø 1.0in[25mm]
 ▽ 2.0in[50mm]-
 ▽ 2.5in[66mm]

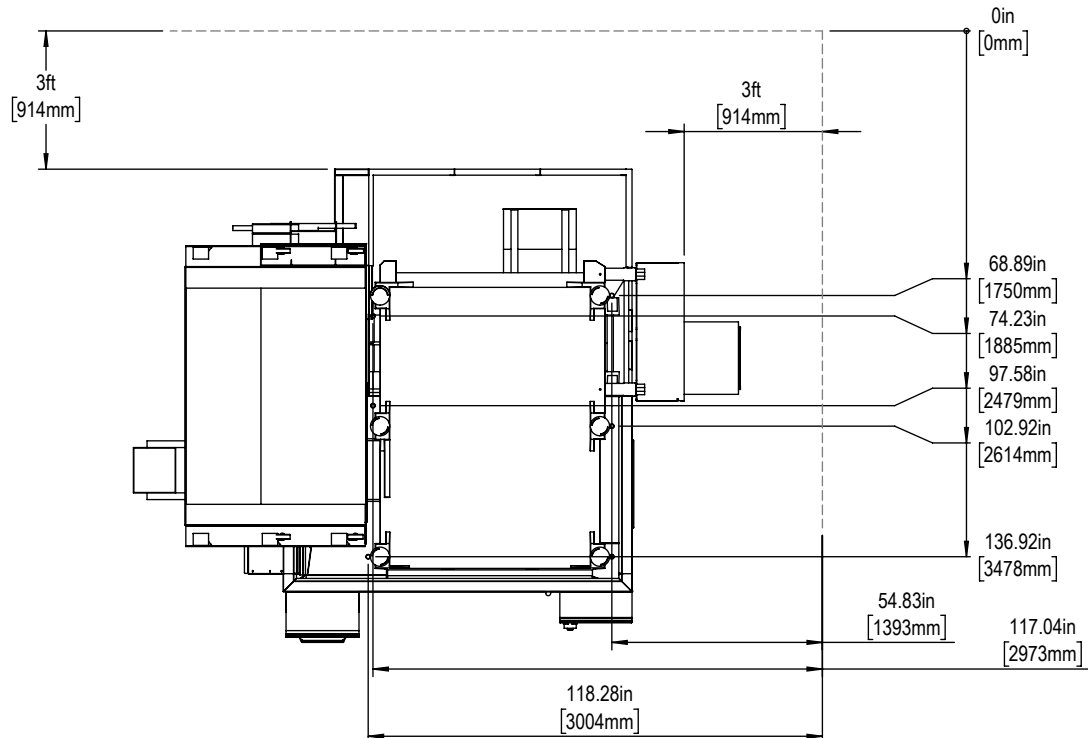

For precise locations and specifications please use template in Anchoring Kit found at Haascnc.com

Height Breakdown

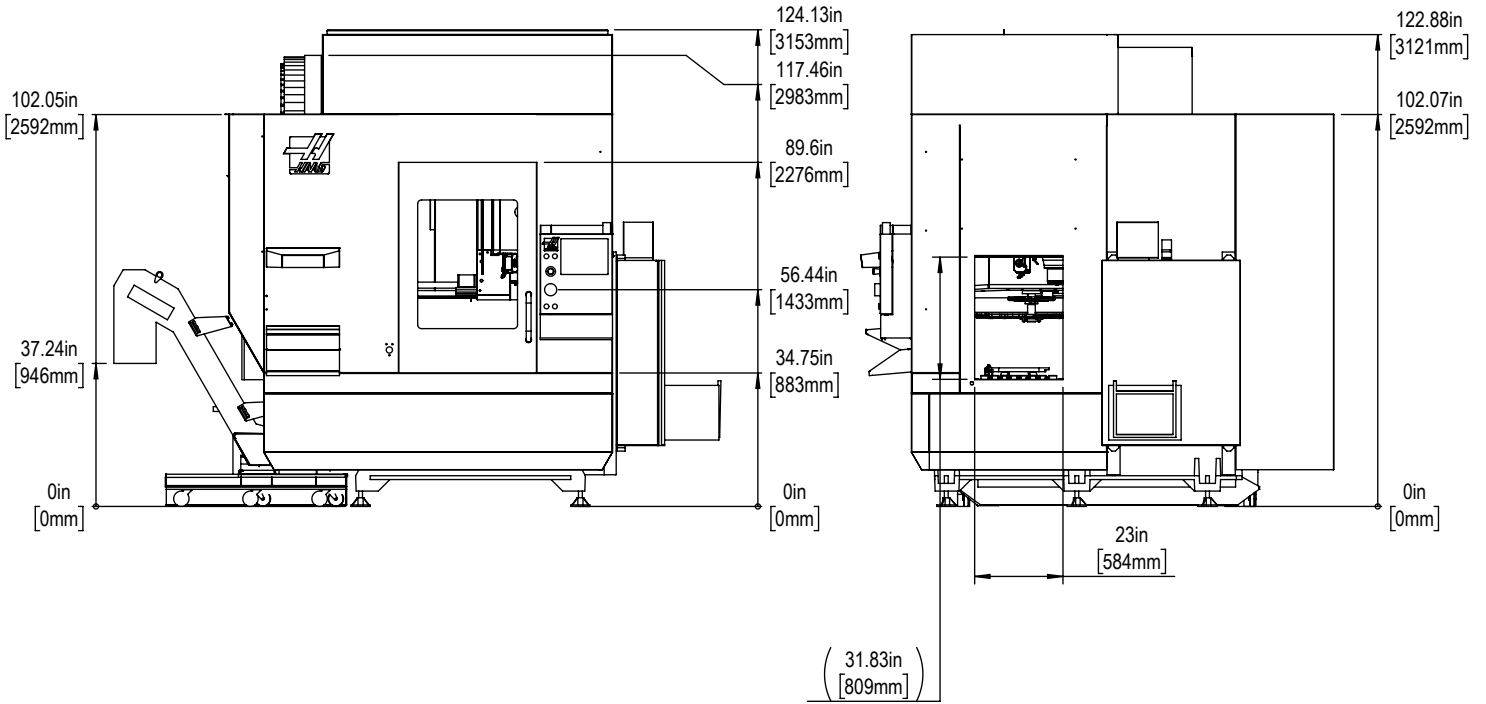

Width Breakdown

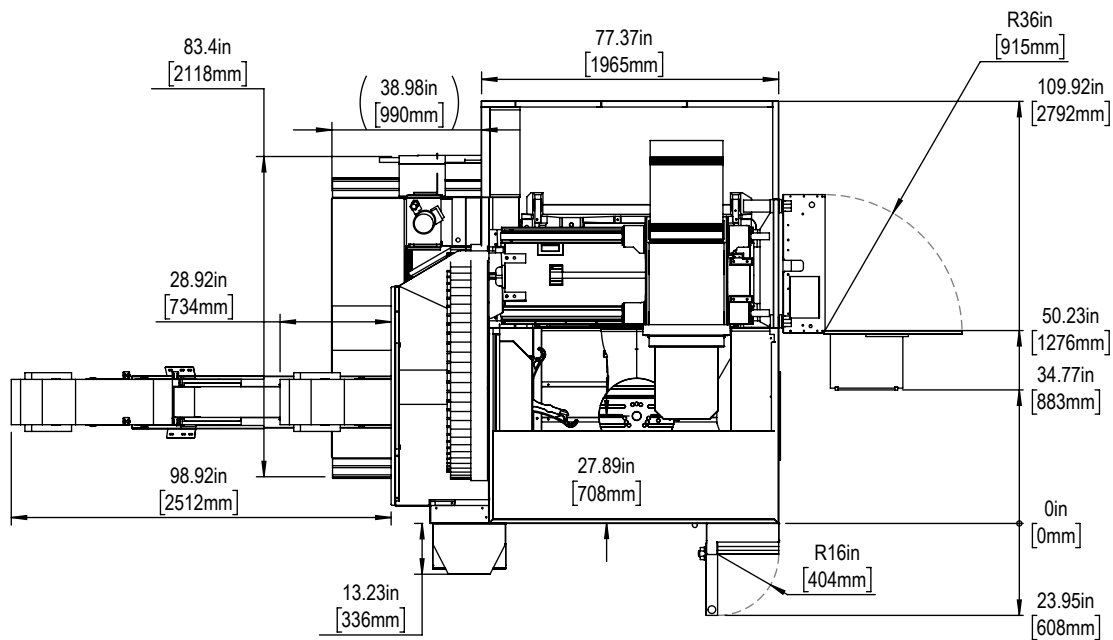

For precise locations and specifications please use template in Anchoring Kit found at Haascnc.com



Clearance at B90

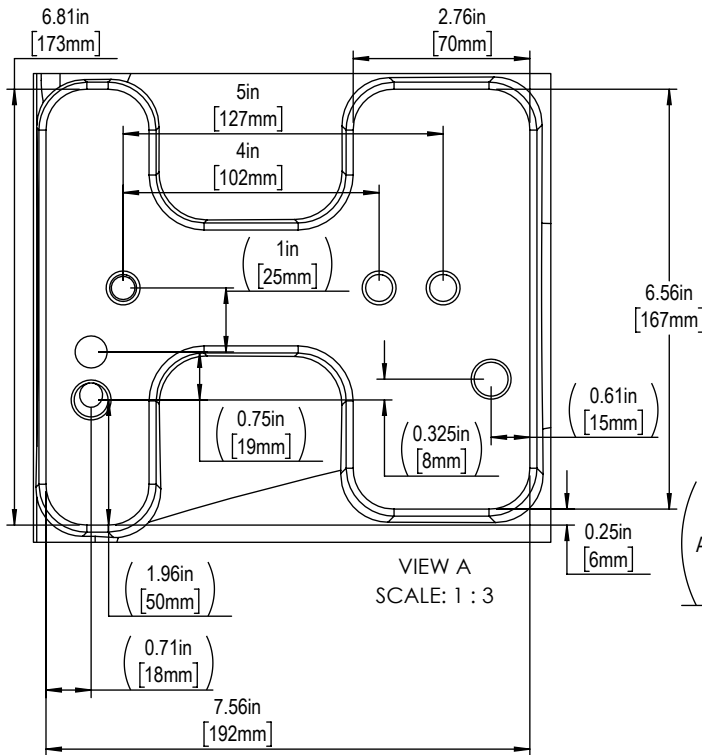

VIEW A
SCALE: 1 : 3

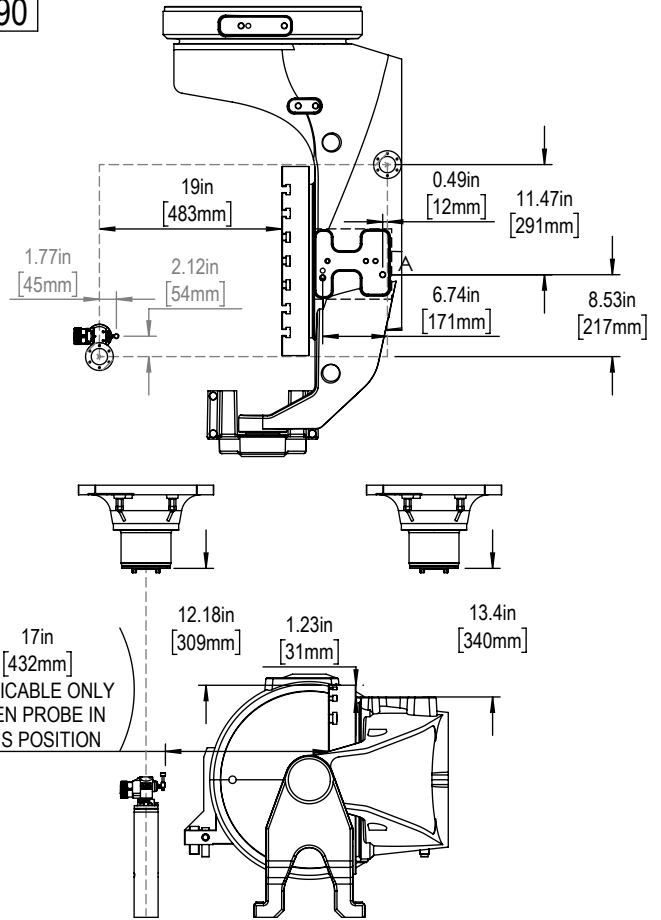

Work Envelope

(Tool Length + Workpiece Height)
< 23.0in [585mm]
Maximum Combined Height*

*Note - Maximum height and swing apply to B0 orientation only. Large workpieces, including ones within the stated work envelope, may interfere with other machine components as the tilt angle increases. If your part is larger than 20.0in [500mm] diameter or taller than 18in [460mm] it is recommended to review your application's suitability with your local HFO Applications team

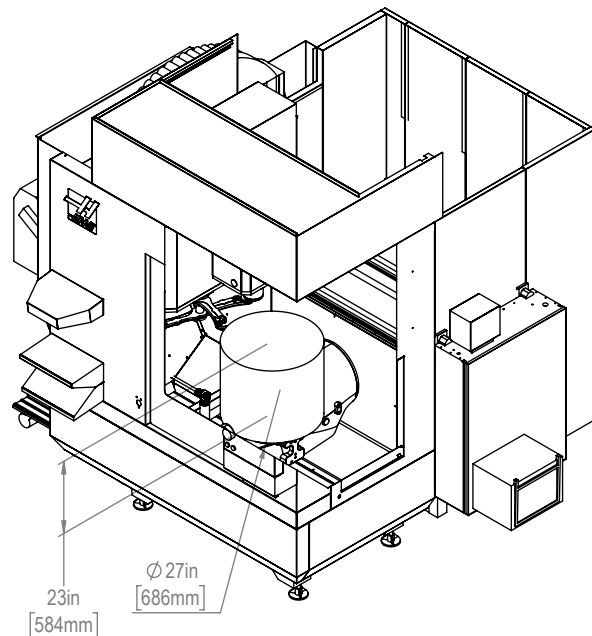



Table

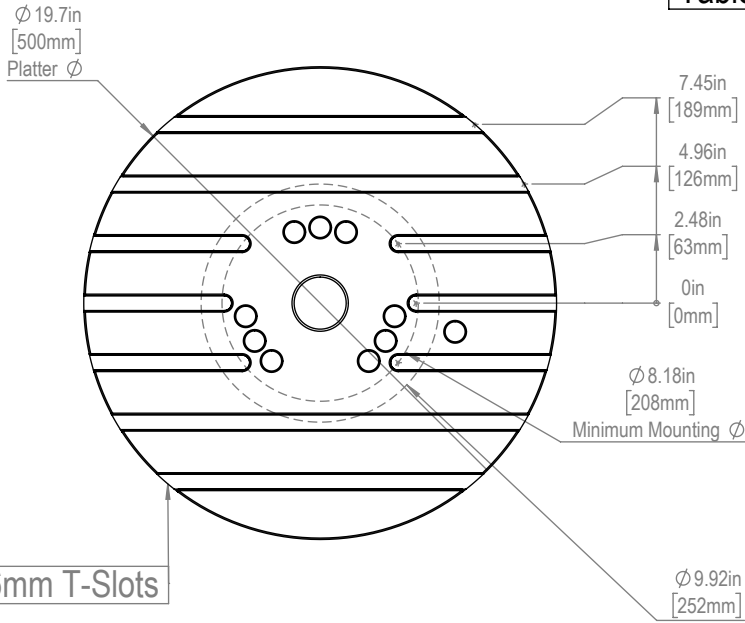

Note:

1. (10x) Phantom holes are not available to use for part fixturing
2. It is possible to route a hydraulic or pneumatic hose thru the trunnion to center of the platter to accommodate automatic workholding with the following considerations
 1. A sealed rotary union must be used. The center bore leads directly to the trunnion cavity. An unsealed union will allow coolant and chips to penetrate the interior and cause damage
 2. From the factory there is a plug installed. The plug should be knocked out thru the bottom of the trunnion, or drilled thru to accommodate the sealed union
 3. The hoses should be sufficiently retained such that they do not interfere with any other components

16mm T-Slots

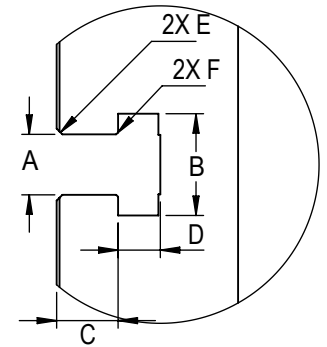

T-Slot Dimensions in inches

Slot Size	A	B	C	D	E	F
12mm	$0.438^{+0.002}_{-0.000}$	0.76 ± 0.02	0.310 ± 0.010	0.318 ± 0.010	$0.03 \times 45^\circ$	$0.020 \times 45^\circ$
16mm	0.628 ± 0.002	1.06 ± 0.02	0.640 ± 0.010	0.420 ± 0.010	$0.06 \times 45^\circ$	$0.020 \times 45^\circ$

Tool Changer

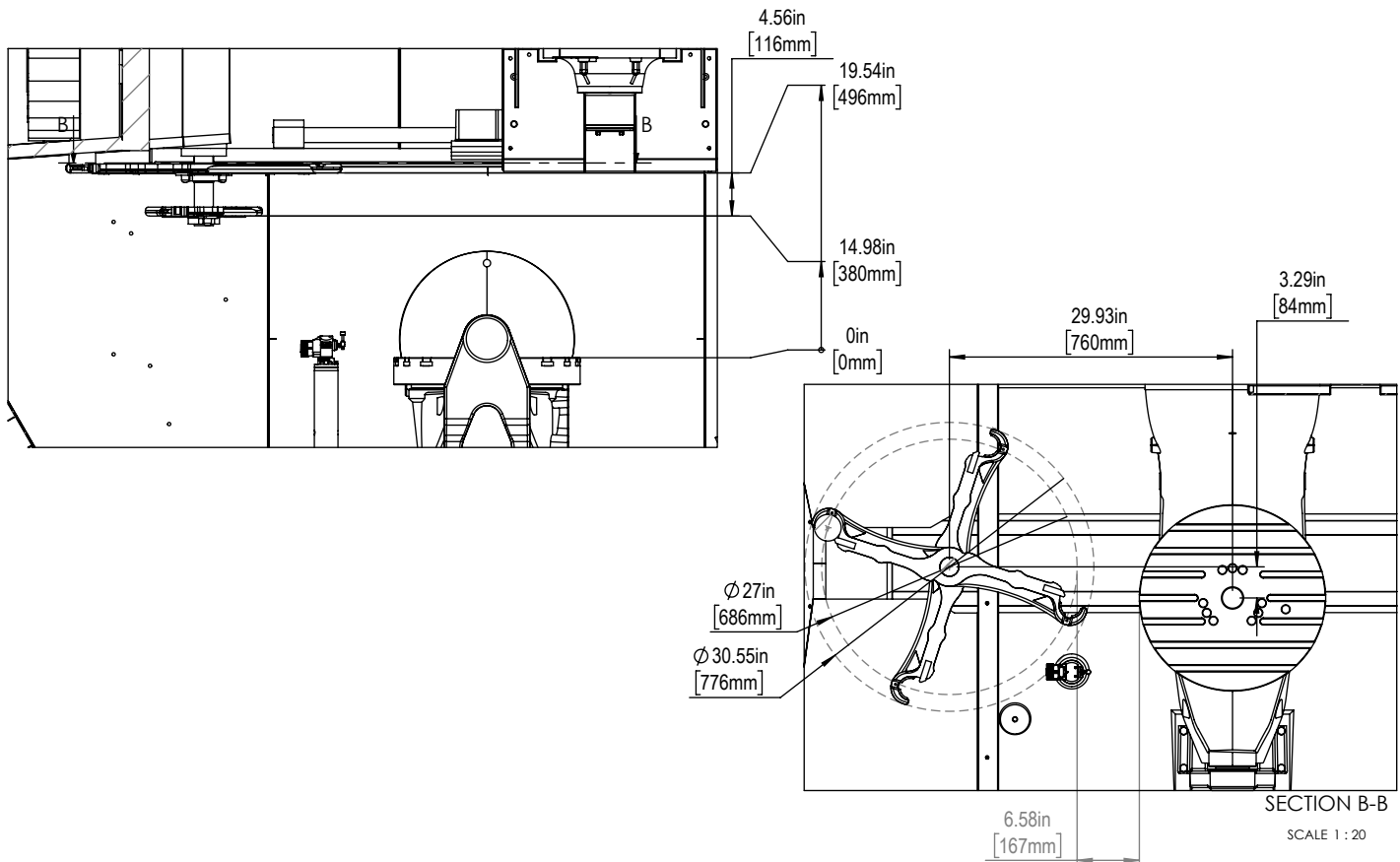

SECTION B-B

SCALE 1 : 20

Machine Layout Drawing - UMC-750/SS/P (2012-2019)

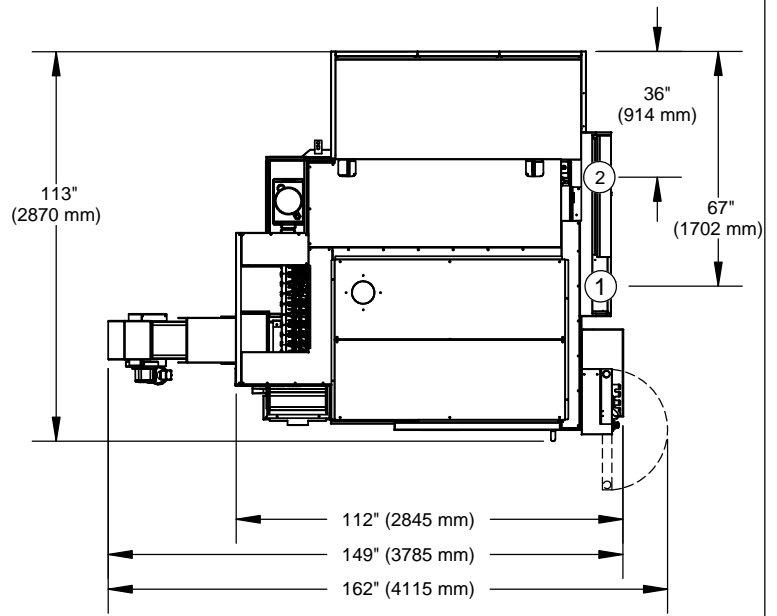
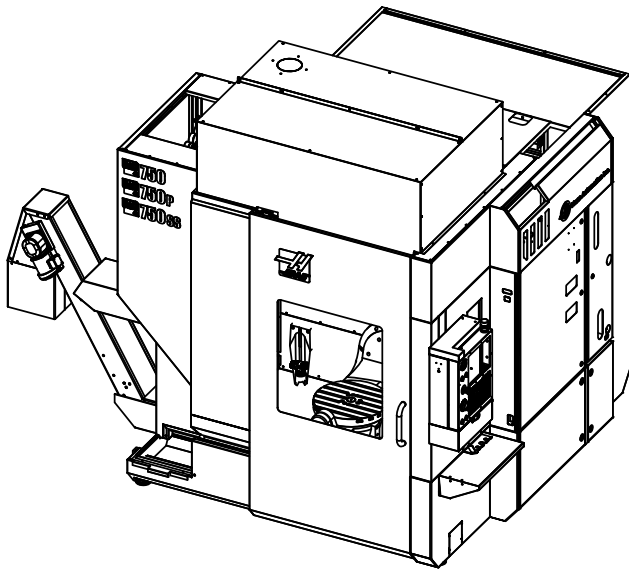

Note:
Minimum distance required to remove conveyor from mill 85" (2159 mm)

- ① Electrical Connection
- ② Air Connection

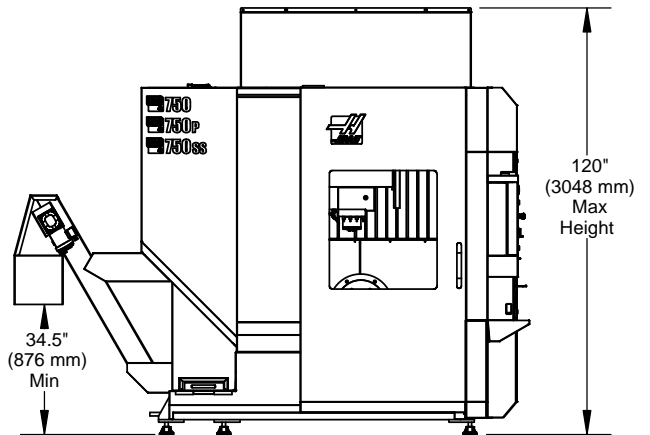
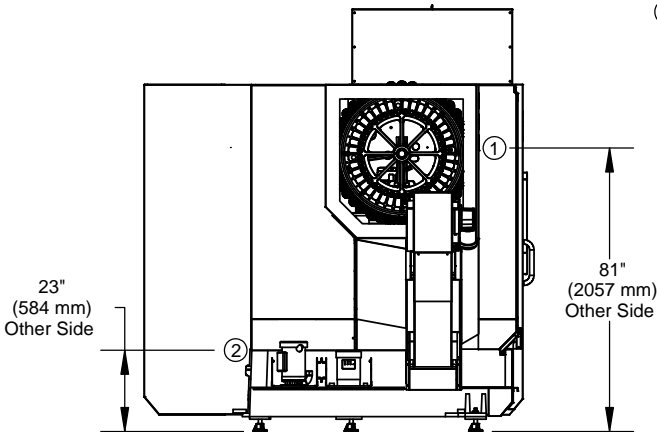

Operating Dimensions

Note:
The roof is a standard feature as of Q1 2018

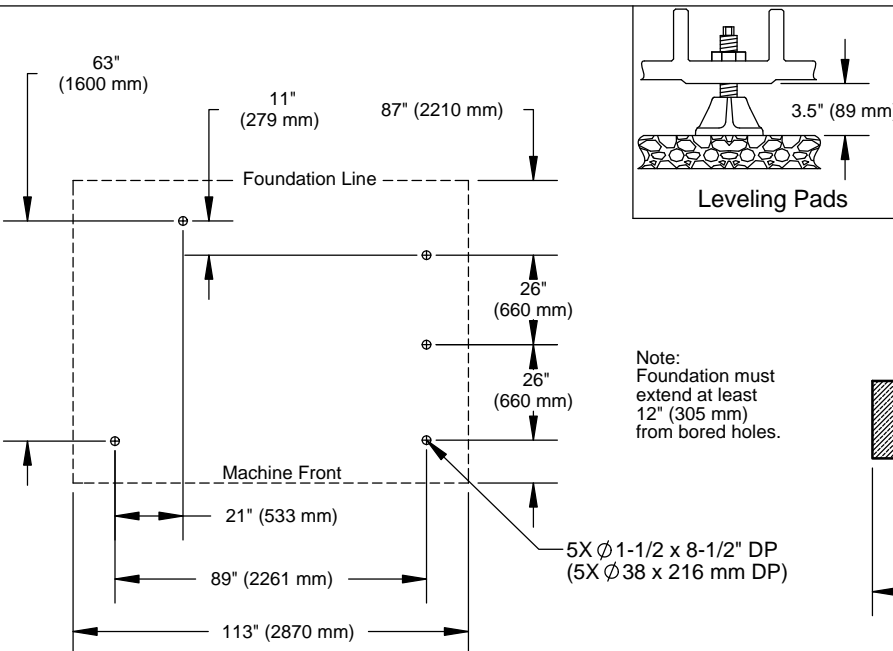

Note:
Foundation must extend at least 12" (305 mm) from bored holes.

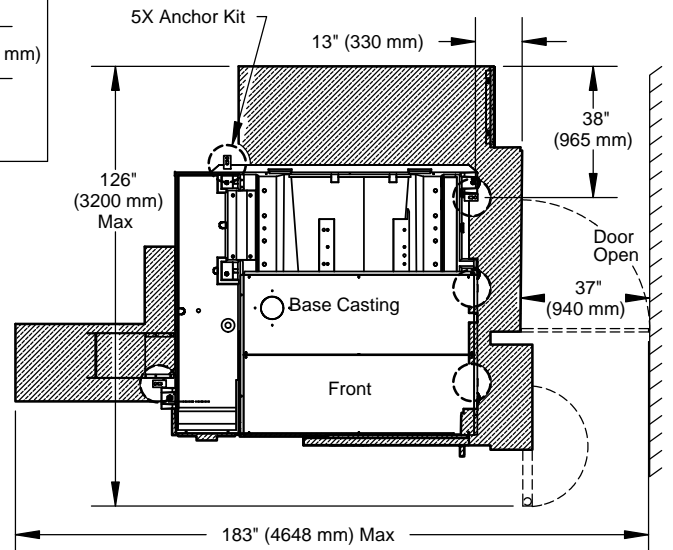

Anchor Pattern

*Due to continual product improvements, machine dimensions are subject to change without notice.

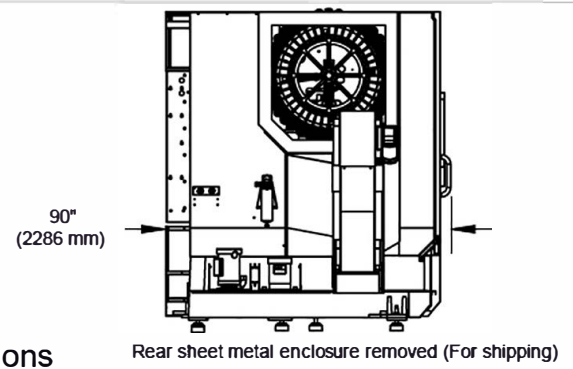
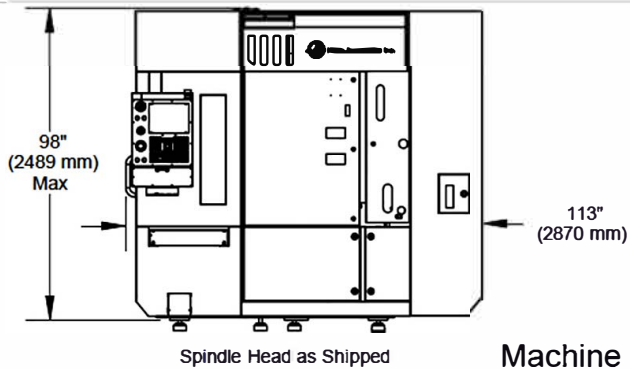

Machine Clearance Dimensions

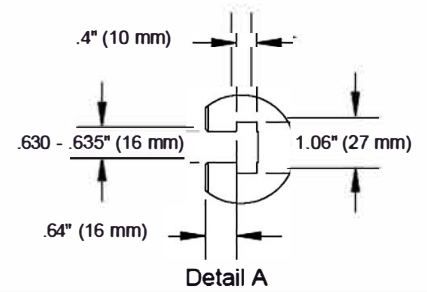
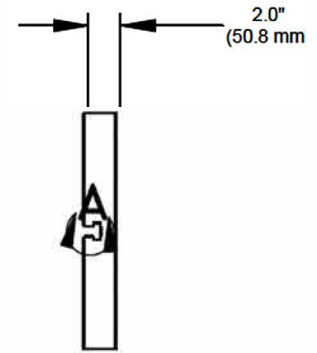
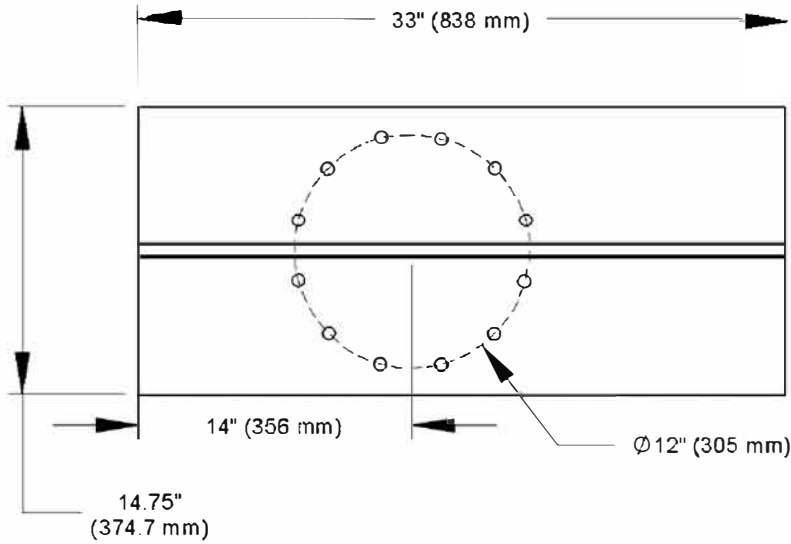

UMC-750P Table Dimensions

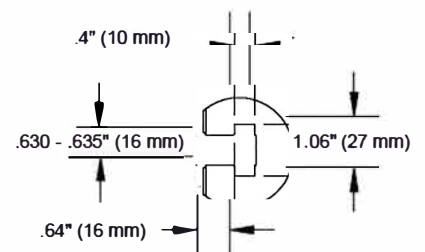
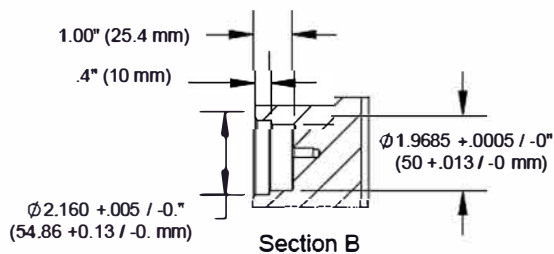
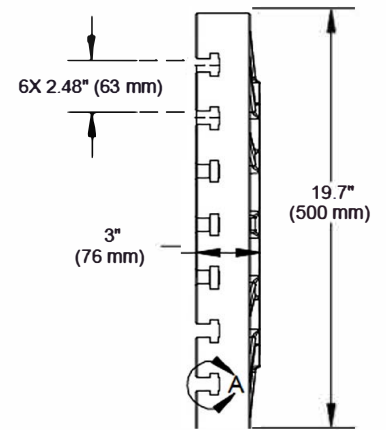
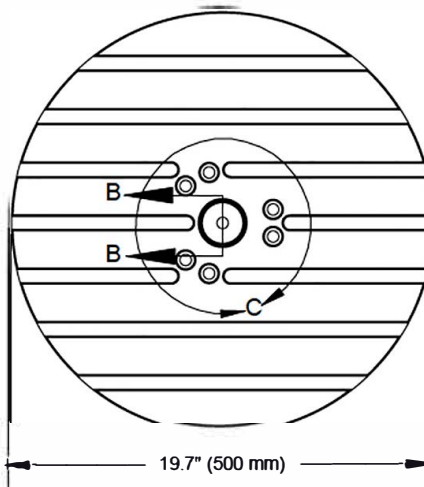
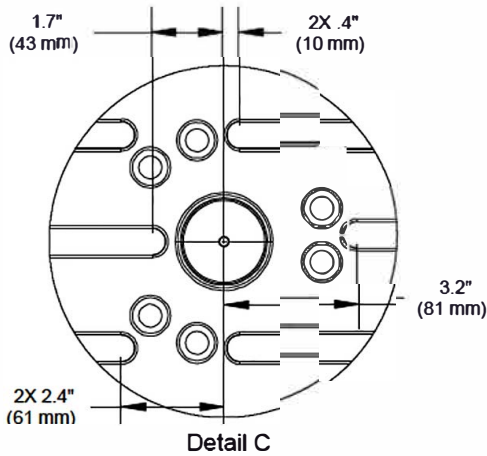

UMC-750/SS Table Dimensions

*Due to continual product improvements, machine dimensions are subject to change without notice.

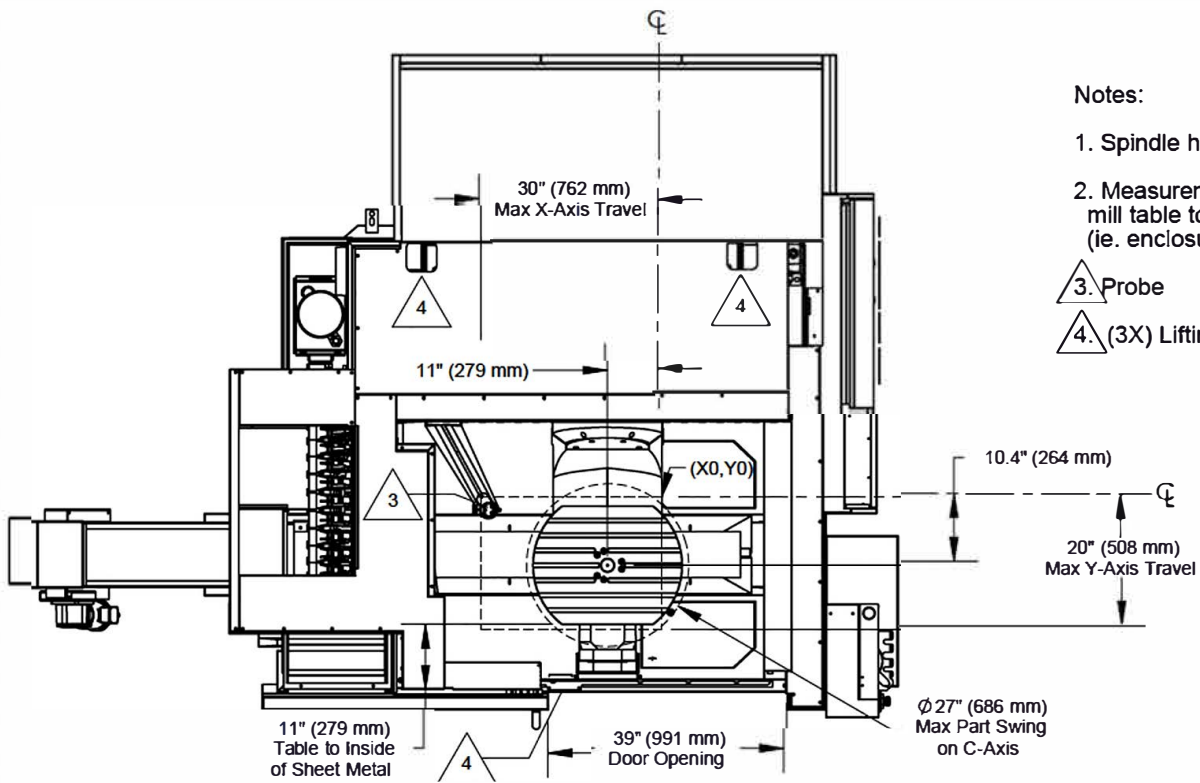

Machine Travels

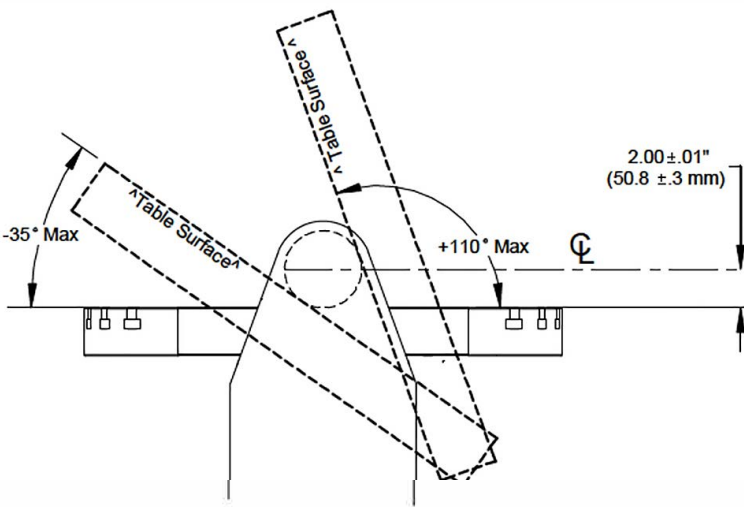

B-Axis Work Envelope

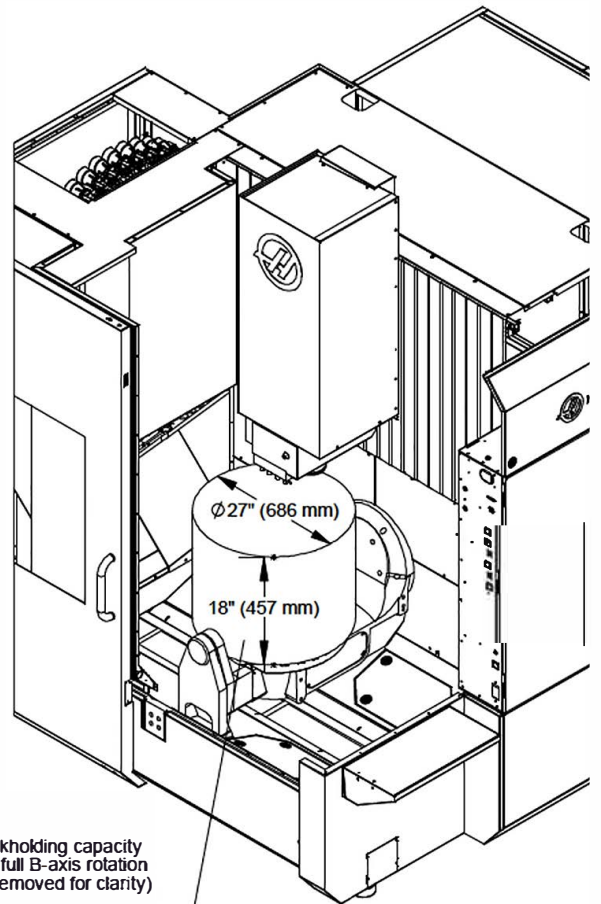

Enclosure Work Space

*Due to continual product improvements, machine dimensions are subject to change without notice.

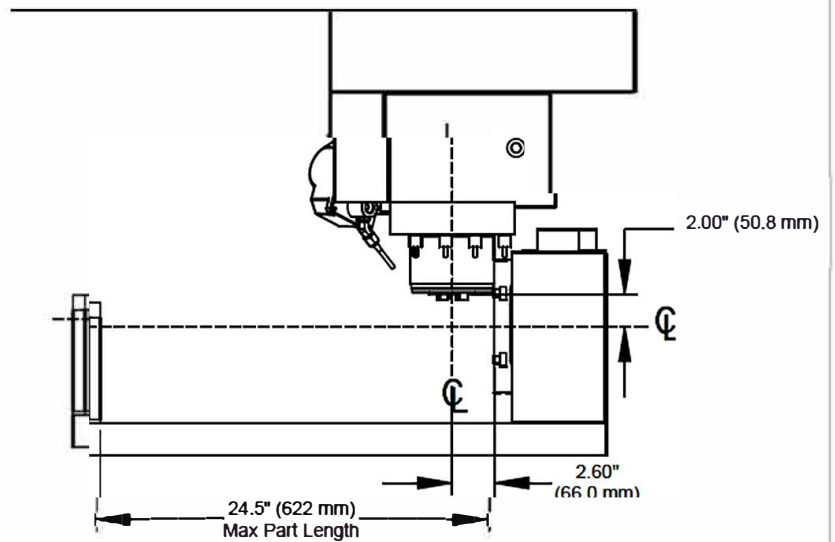
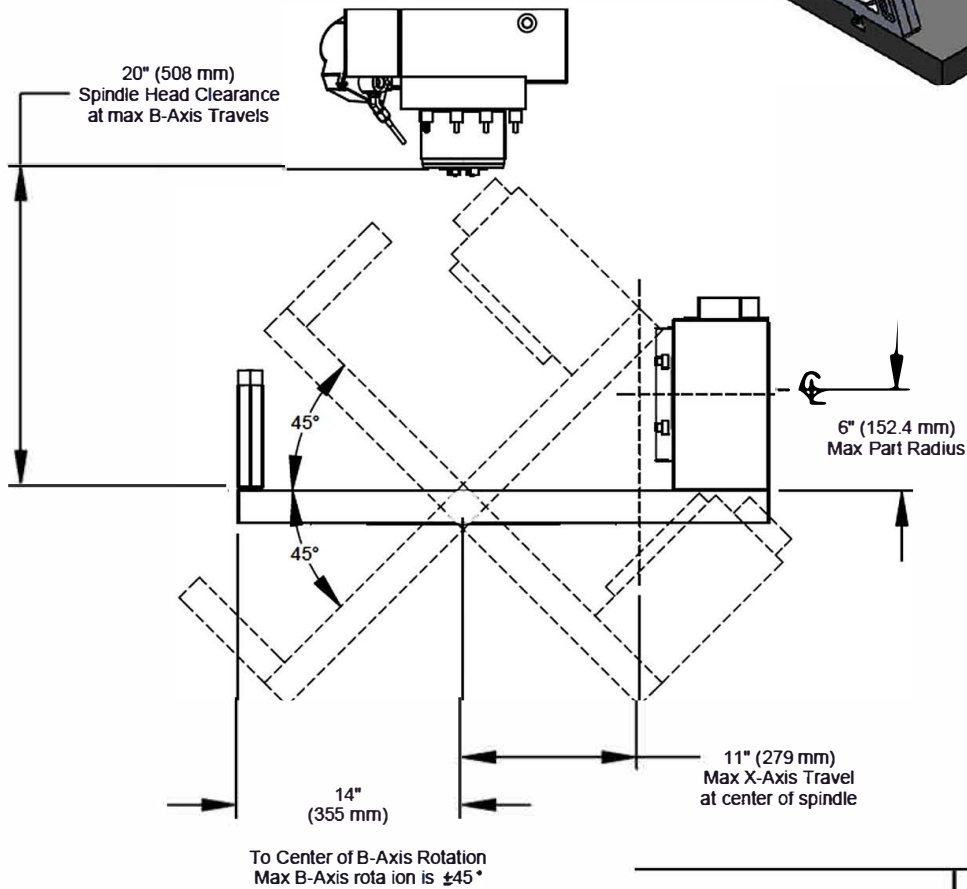
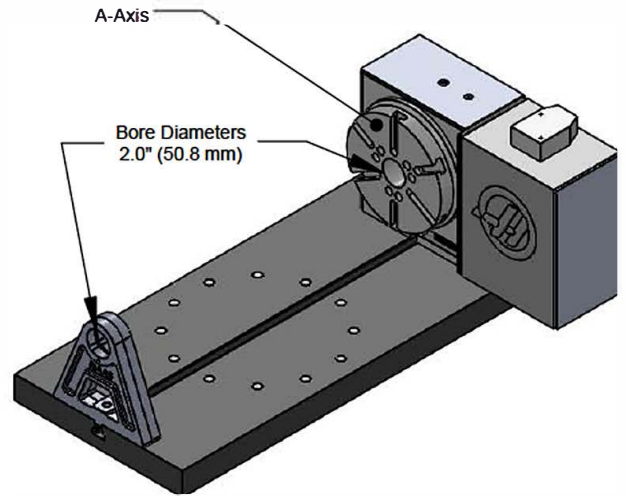

This view shows the spindle head clearance with a 2" (50.8 mm) long tool, which is 3" (76.2 mm) above the minimum clearance

UMC-750P Table/Rotary Dimensions

*Due to continual product improvements, machine dimensions are subject to change without notice.

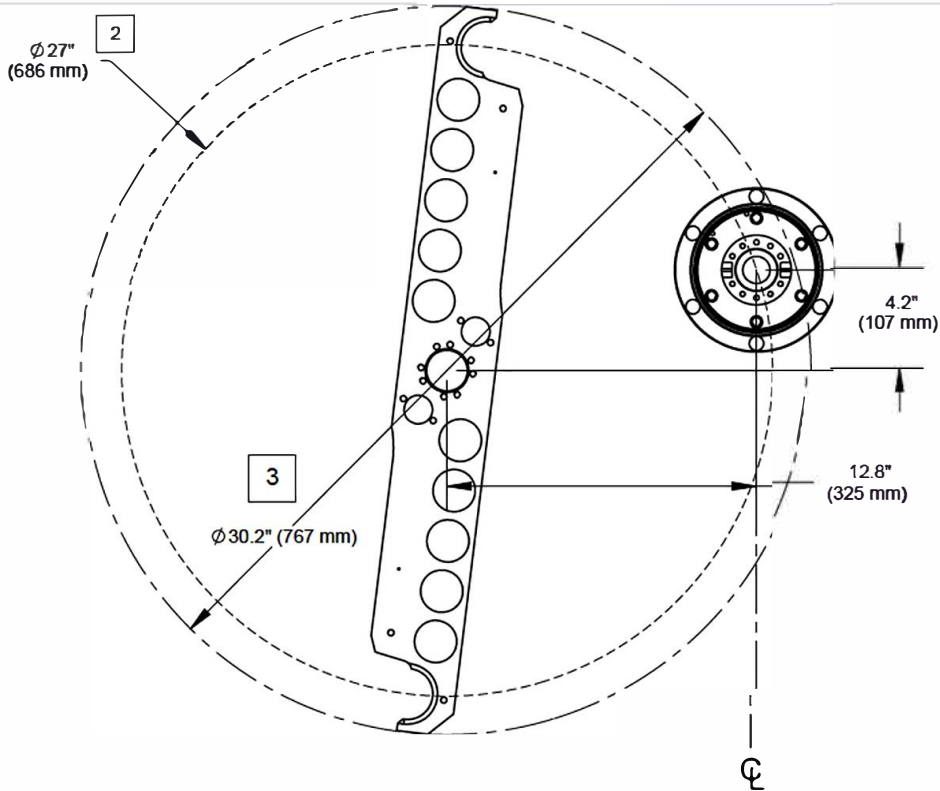

Notes:

1. Double arm swings down 4.5" (114 mm).
2. Double arm swing diameter.
3. Overall length of arm.

40 Taper 40+1 Side-Mount Tool Changer Double Arm Work Envelope

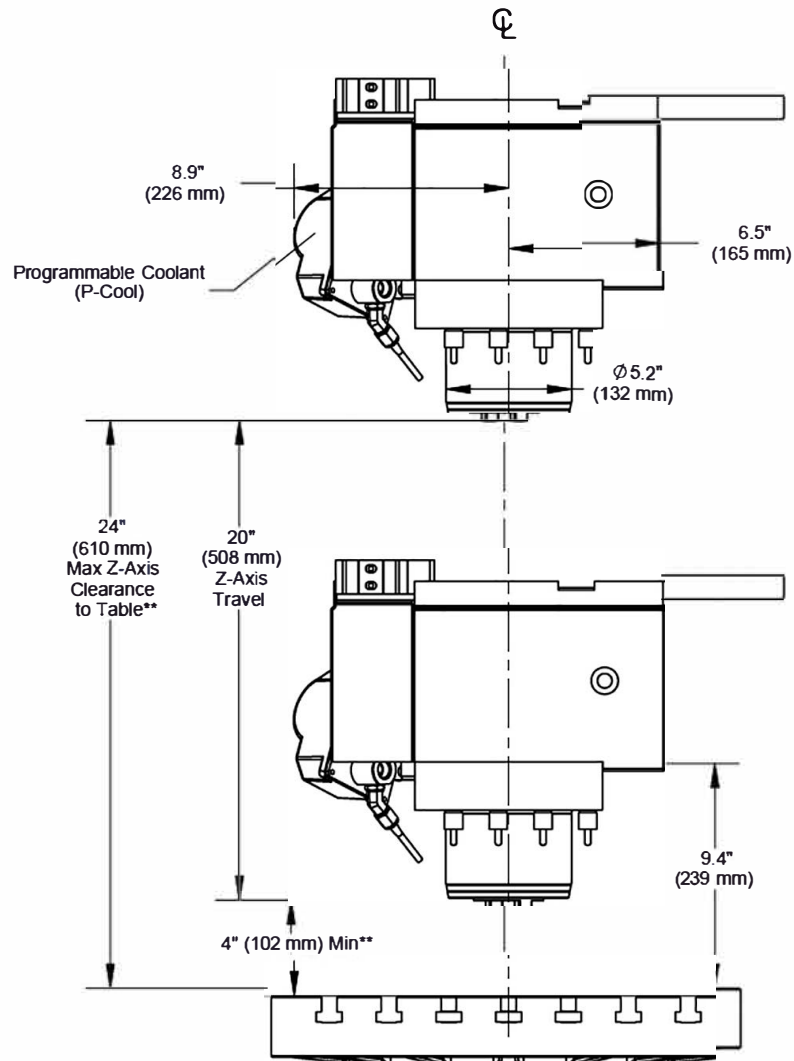

**The UMC-750P's table is 1" (25.4 mm) shorter than the standard table, clearance is 5-25" (127-635 mm)

Spindle Head Clearances

*Due to continual product improvements, machine dimensions are subject to change without notice.